

At Salsa, we believe that a sense of adventure makes life better. The bicycle can be so much more than just a bike; it's a path to new places, new people, and amazing experiences.

Thank you for your purchase. We hope it makes a good riding experience even better!

Salsa. Adventure by bike®.

**▲ WARNING:** CYCLING CAN BE DANGEROUS. BICYCLE PRODUCTS SHOULD BE INSTALLED AND SERVICED BY A PROFESSIONAL MECHANIC. NEVER MODIFY YOUR BICYCLE OR ACCESSORIES. READ AND FOLLOW ALL PRODUCT INSTRUCTIONS AND WARNINGS INCLUDING INFORMATION ON THE MANUFACTURER'S WEBSITE. INSPECT YOUR BICYCLE BEFORE EVERY RIDE. ALWAYS WEAR A HELMET.

### Compatibility & Intended Use

Lip-Lock and Rack-Lock are available in these assorted sizes: 28.6, 30.0, 30.6, 32.0, 35.0, and 36.4mm.

Flip-Lock is available in these assorted sizes: 28.6, 30.0, 30.6, 32.0, 35.0, and 36.4mm.

Please check with your frame manufacturer for the correct size.

Post-Lock is available for 27.2 and 31.6mm seatposts.

**▲ WARNING:** the Post-Lock is only intended to provide a rack mount on small frames or on frames without rack mounting eyelets; it CANNOT be used as a seatpost collar.

**▲ WARNING:** the Post-Lock is not for use on carbon seatposts unless specified by seatpost manufacturer. Excess weight or stress on a carbon post that is not designed for an extra attachment could cause failure resulting in serious injury.

**▲ WARNING:** incorrectly sized seatpost collars could cause the seatpost to slip while riding and lead to serious injury.

**NOTE:** Make sure that your frame seat tube is free of any burrs or peeled paint. It may be necessary to gently sand the frame to achieve a smooth finish.

### Tools:

5mm Allen wrench

Torque wrench

Grease

### Lip-Lock & Rack-Lock Installation

1. Apply a thin layer of grease to the top of your seat tube.
2. Slide the collar onto your frame. The slot in the collar should be over the slot in the seat tube of your frame, and the inner lip of the collar should sit flush on top of the seat tube.

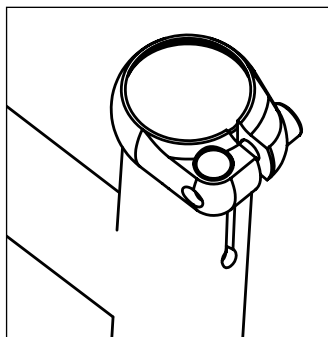

## FLIP-LOCK, LIP-LOCK, RACK-LOCK, & POST-LOCK INSTRUCTIONS

3. Tighten the M6 bolt with a 5mm Allen wrench to 8Nm or manufacturer's recommended frame/post torque setting, whichever is lowest.

### Flip-Lock Installation

1. Apply a thin layer of grease to the top and inside of your seat tube.
2. Slide the collar onto your frame. The slot in the collar should be over the slot in the seat tube of your frame, and the inner lip of the collar should sit flush on top of the seat tube.
3. Make sure the quick-release lever is in the open position, and place the seatpost into the frame.
4. Seat the lever's cam in the cam follower and, with the lever in the open position, rotate the lever arm forward or backward depending on the proper orientation with the slot in your frame.
5. Swing the lever into the fully closed position. The last 30 to 40° of lever movement should require considerable force (24–30 lb). If the resistance is less than this, open the quick-release lever and adjust the tension by tightening the M6 bolt on the opposite side of the lever incrementally until the closing action of the lever requires the recommended amount of force. The seatpost is now firmly locked in place.

### Post-Lock Installation

**NOTE:** Check for compatibility with the manufacturer of the seatpost before installing the Post-Lock.

1. Apply a thin layer of grease to the inside of the Post-Lock.
2. Slide the Post-Lock onto your seatpost to the desired position.
  - ▲ WARNING:** The seatpost must be inserted into the frame below the minimum insertion line. The slot in the collar should face the rear of the bike.
3. Tighten the M6 bolt until the Post-Lock cannot twist or slide on the seatpost without exceeding the collar or seatpost's maximum torque. If no information is available from the manufacturer, tighten to 3–5Nm.

### Ongoing Maintenance

Periodically make sure the Flip-Lock, Lip-Lock, Rack-Lock, or Post-Lock is tightened to the proper torque.

### Warranty Information:

Proof of purchase is required before a warranty claim is processed. Salsa Cycles therefore strongly encourages warranty registration at [salsacycles.com](http://salsacycles.com). Failure to register will not affect consumer rights, so long as the consumer can show in a reasonable manner proof of original ownership and the date the Salsa Cycles product was purchased.

If you have any questions contact [warranty@salsacycles.com](mailto:warranty@salsacycles.com) or visit [www.salsacycles.com/support](http://www.salsacycles.com/support) for more warranty information.

### SALSA CYCLES

6400 West 105th Street, Bloomington, MN 55438

Tel: 877-MOTO-ACE Fax: 952-983-6210

[www.salsacycles.com](http://www.salsacycles.com)