



SUSPENSION FRAME SERVICE - SHOCK MOUNT HARDWARE INSTRUCTIONS

At Salsa, we believe that a sense of adventure makes life better. The bicycle can be so much more than just a bike; it's a path to new places, new people, and amazing experiences.

Thank you for your purchase. We hope it makes a good riding experience even better!

Salsa. Adventure by bike.®

▲ WARNING: Cycling can be dangerous. Bicycle products should be installed and serviced by a professional mechanic. Never modify your bicycle or accessories. Read and follow all product instructions and warnings including information on the manufacturer's website. Inspect your bicycle before every ride. Always wear a helmet.

Compatibility & Intended Use

These instructions cover service and replacement of the forward shock pin hardware located in the front triangle, which fixes the forward end of the rear shock to the frame. The hardware used varies across frame model and material. Determine which kit is correct for your frame from the list below.

Required Hardware

Hardware kits required to service this area include:

- 1594 Shock Mount Hardware Kit which is compatible with MY19+ Spearfish Aluminum (all spec levels)
MY19+ Horsethief Aluminum (all spec levels)
MY19+ Rustler Aluminum (all spec levels)
- 1595 Shock Mount Hardware Kit which is compatible with: MY19+ Spearfish Carbon (all spec levels)
MY19+ Horsethief Carbon (all spec levels)
MY19+ Rustler Carbon (all spec levels)

Replacement eyelet-reducing hardware for the rear shock must be ordered separately. See table below for specification/size for each frame model.

Tools & Supplies Required

- Torque wrench
- 5mm hex bit
- Lightweight grease

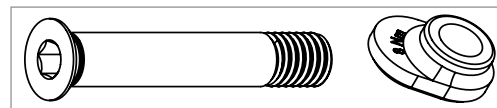
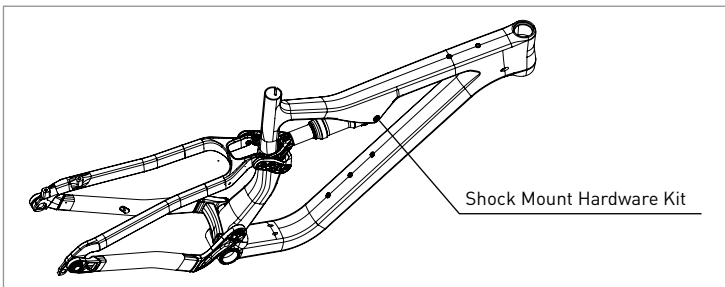

1594 Shock Mount Hardware Kit

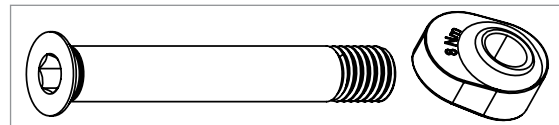

1595 Shock Mount Hardware Kit

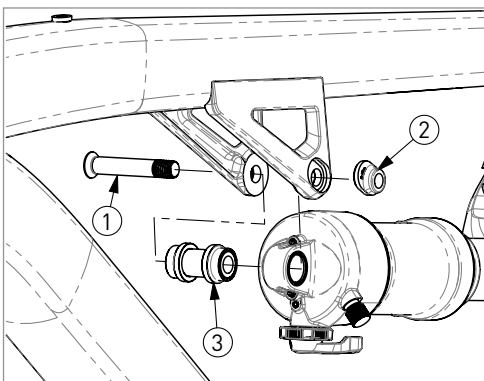

1594 Shock Mount Hardware

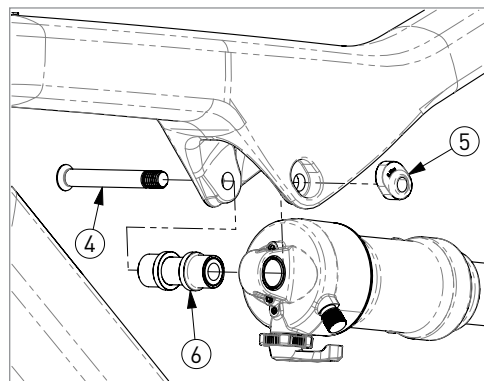

1595 Shock Mount Hardware

Item #	Description	Item Notes	Found in Kit #	Qty.	Applies to	Tools	Prep	Torque
1	1223 Flathead Pin	M8 x 1.25, 47mm total length	1594	1	MY19+ Spearfish Aluminum MY19+ Horsethief Aluminum MY19+ Rustler Aluminum	5mm hex bit	Loctite Blue 242® on threads, lightly grease frame pockets	8Nm (71 in-lb)
2	1346 Shock Mount Nut	M8 x 1.25	1594	1		--		
3	Shock Eyelet Reducer	Ø8 x 30mm wide	--	1 req.		Arbor press/eyelet tool	Clean shock bushing	--
4	1222 Flathead Pin	M8 x 1.25, 60mm total length	1595	1	MY19+ Spearfish Carbon MY19+ Horsethief Carbon MY19+ Rustler Carbon	5mm hex bit	Loctite Blue 242® on threads, lightly grease frame pockets	8Nm (71 in-lb)
5	1074 Shock Mount Nut	M8 x 1.25	1595	1		--		
6	Shock Eyelet Reducer	Ø8 x 40mm wide	--	1 req.		Arbor press/eyelet tool	Clean shock bushing	--



SUSPENSION FRAME SERVICE - SHOCK MOUNT HARDWARE INSTRUCTIONS

Recommended Service Intervals

Shock Eyelet-Reducing Hardware:

If play develops between the eyelet reducers and the pin, shock, or frame, OR if bushing action is not smooth. This may occur every 1–2 years depending on riding frequency and environment.

All Pivot Hardware:

If play is still present with new eyelet-reducing hardware or if hardware is damaged or lost.

Pin & Nut Service

- Apply a thin coat of grease to the frame pockets
- Apply a thin coat of grease to the shank portion of the bolt
- Apply a drop of thread-locking agent (Loctite Blue 242®) if desired

Eyelet-Reducing Hardware Service

- Remove and isolate the rear shock from the rest of the frame before removing or installing eyelet-reducing hardware
- Refer for shock manufacturer's instructions for proper bushing and eyelet-reducing hardware service
- Refer to the Flip Chip Shock Mount Hardware instructions for servicing hardware at the rear end of the rear shock

Ongoing Maintenance

- Check pivots before every ride, tighten to specified torque as needed. Applying thread lock as described helps to prevent bolts from loosening during normal riding conditions
- Inspect pivot hardware for wear/damage at least annually. If pivot hardware becomes damaged, stripped, or develops play that cannot be eliminated with the proper torque specification, replace the affected part(s)
- Check bearings for smooth operation at least annually (more often depending on frequency and riding environment). If bearings are rough, seized, or there is slop between the inner and outer bearing race, replace as needed

Warranty

Salsa Cycles warrants this new Salsa product against defects in materials and workmanship for two (2) years from the original date of retail purchase by the consumer. This limited warranty is expressly limited to the repair or replacement of the original product, at the option of Salsa Cycles, and is the sole remedy of the warranty. This limited warranty applies only to the original purchaser of the Salsa product and is not transferable. In no event shall Salsa Cycles be liable for any loss, inconvenience or damage, whether direct, incidental or consequential or otherwise resulting from breach of any express or implied warranty or condition, of merchantability, fitness for a particular purpose, or otherwise with respect to this product except as set forth herein.

This warranty does not cover the following:

- Damage due to improper assembly or follow-up maintenance or lack of skill, competence or experience of the end user
- Products that have been modified, neglected, used in competition or for commercial purposes, misused or abused, involved in accidents or anything other than normal use
- Damage or deterioration to the surface finish, aesthetics or appearance of the product
- Normal wear and tear
- Labor required to remove and/or refit and re-adjust the product within the bicycle assembly

To the extent not prohibited by law, these warranties are exclusive and there are no other express or implied warranties or conditions including warranties or conditions of merchantability and fitness for a particular purpose.

Proof of purchase is required before a warranty claim is processed. Salsa Cycles therefore strongly encourages warranty registration at salsacycles.com. Failure to register will not affect consumer rights under the limited warranty stated above, so long as the consumer can show in a reasonable manner proof of original ownership and the date the Salsa Cycles product was purchased.

If you have any questions contact warranty@salsacycles.com or visit www.salsacycles.com/support for more warranty information.

SALSA CYCLES

6400 West 105th Street, Bloomington, MN 55438

Tel: 877-668-6223 Fax: 952-983-6210

www.salsacycles.com