



## 465 DERAILLEUR HANGER INSTRUCTIONS

At Salsa, we believe that a sense of adventure makes life better. The bicycle can be so much more than just a bike; it's a path to new places, new people, and amazing experiences.

Salsa. Adventure by bike.®

Thank you for purchasing a Salsa! We want to give you important information about your bike...

**▲ WARNING:** Cycling can be dangerous. Bicycle products should be installed and serviced by a professional mechanic. Never modify your bicycle or accessories. Read and follow all product instructions and warnings including information on the manufacturer's website. Inspect your bicycle before every ride. Always wear a helmet.

### Compatibility and Intended Use

The 465 hanger is compatible with all Salsa suspension frames featuring Split Pivot technology, as well as the second generations of the Beargrease Carbon, Warbird, Warroad, Cutthroat, and frames equipped with flat-mount alternator plates.

### Tools

8mm hex key socket (Warbird, Warroad, Cutthroat, and flat-mount alternator only)

22mm socket w/ no lead-in chamfer (Suspension and Beargrease only\*)

Torque wrench

Loctite 243 thread locking compound

**\*NOTE:** Salsa Split Pivot Dropout Tool Top Cap can be used with a 6mm hex key socket and torque wrench in place of 22mm socket for Suspension and Beargrease.

### Hanger Replacement / Installation

Refer to the appropriate Figure for your bike while executing the steps below.

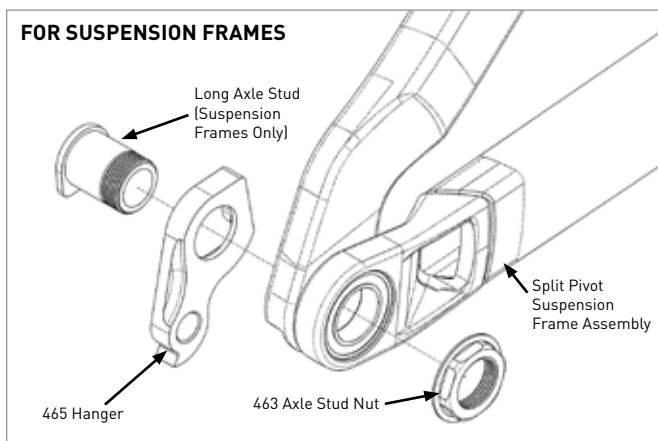

Figure 1

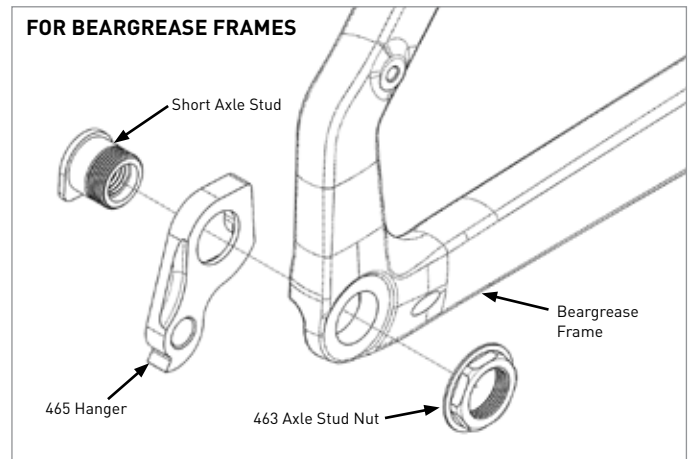

Figure 2

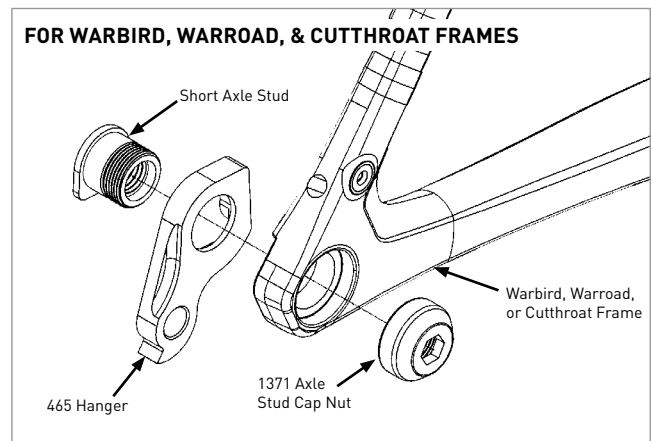

Figure 3

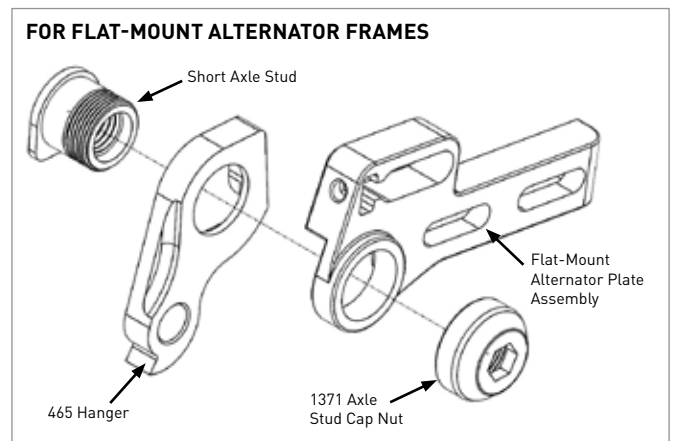

Figure 4



## 465 DERAILLEUR HANGER INSTRUCTIONS

1. Remove the rear thru-axle per the axle manufacturer's instructions.
2. Remove the rear wheel.
3. Remove the rear derailleur per manufacturer's instructions and let hang out of the way gently by the cable housing.
4. Remove the axle stud nut:  
**Suspension and Beargrease:** Using a 22mm socket with no lead-in chamfer, loosen and remove the 463 Axle Stud Nut from the drive side by turning the nut in a counter-clockwise direction.  
**Warbird, Warroad, Cutthroat, and Flat-Mount Alternator:** Using an 8mm hex key socket, loosen and remove the 1371 Axle Stud Cap Nut from the drive side by turning the nut in a counter-clockwise direction.
5. Push on the outboard end of the exposed axle stud with your thumb while gently pulling inboard on the hanger tab with your other hand to free the axle stud and hanger assembly from the frame.
6. Separate and discard (recycle) the old/damaged hanger from the axle stud.
7. Inspect the drive side dropout area of the frame for damage. If damage is found, contact your Salsa dealer.
8. Check and clean the frame recess and axle stud of any debris.
9. Place the new hanger onto the axle stud. The stud's head should fit down flush into the pocket on the back of the hanger.
10. Insert the axle stud and hanger assembly back into the frame, making sure the hanger is flush against the inside of the frame's drive side dropout.
11. Apply a small amount of blue thread locking compound to the exposed threads of the axle stud.
12. By hand, start threading the axle stud nut back onto the drive side axle stud.
13. Tighten the axle stud nut:  
**Suspension and Beargrease:** Using a 22mm socket with no lead-in chamfer and torque wrench or Salsa Split Pivot Dropout Tool Top Cap with a 6mm hex key socket, tighten the 463 Axle Stud Nut to 18Nm by turning the nut in a clockwise direction.  
**Warbird, Warroad, Cutthroat, and Flat-Mount Alternator:** Using an 8mm hex key socket and torque wrench, tighten the 1371 Axle Stud Cap nut to 18Nm by turning the nut in a clockwise direction.
14. Reinstall the rear derailleur per manufacturer's instructions.
15. Reinstall the rear wheel.
16. Reinstall the rear thru-axle per manufacturer's instructions.
17. Check rear shifting performance and make any adjustments as needed.

### Ongoing Maintenance

**⚠ WARNING:** Improper installation of bolts may lead to product failure, causing serious injury. Do not exceed specified torque values. Periodically inspect bolts and retighten if required.

Periodically check the rear derailleur mount bolt and tighten if necessary. Periodically check the Axle Stud Nut to make sure it is tight. If it is found to be loose, remove and re-install per steps 11 thru 13 above.

### Warranty Information

Proof of purchase is required before a warranty claim is processed. Salsa Cycles therefore strongly encourages warranty registration at [salsacycles.com](https://salsacycles.com). Failure to register will not affect consumer rights under the limited warranty stated above, so long as the consumer can show in a reasonable manner proof of original ownership and the date the Salsa Cycles product was purchased.

If you have any questions contact [warranty@salsacycles.com](mailto:warranty@salsacycles.com)

### SALSA CYCLES

6400 West 105th Street, Bloomington, MN 55438

Tel: 877-668-6223 Fax: 952-983-6210

[www.salsacycles.com](https://www.salsacycles.com)